

Section A

Answer **all** questions in this section.

A1 A design for a wall clock is shown below.

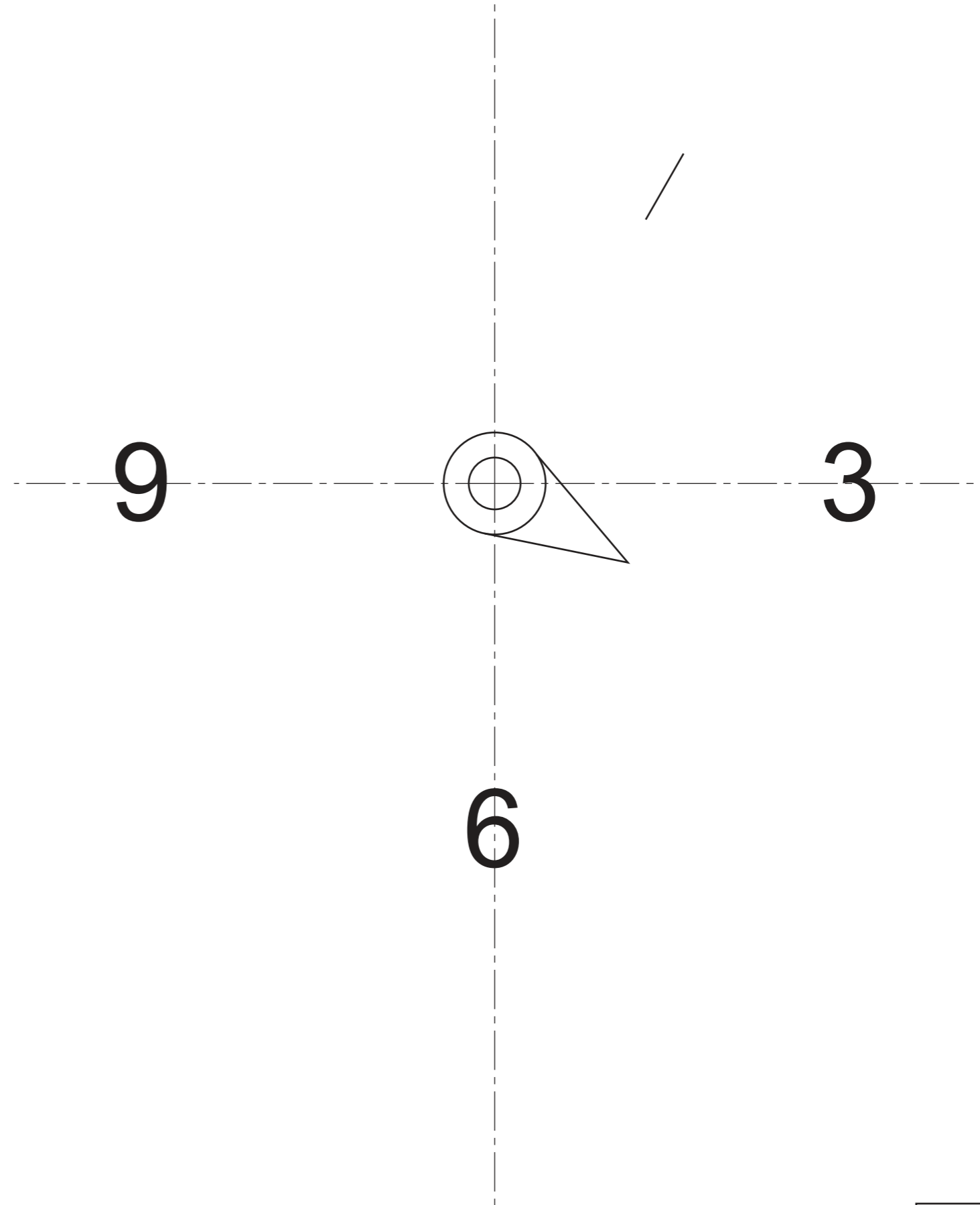
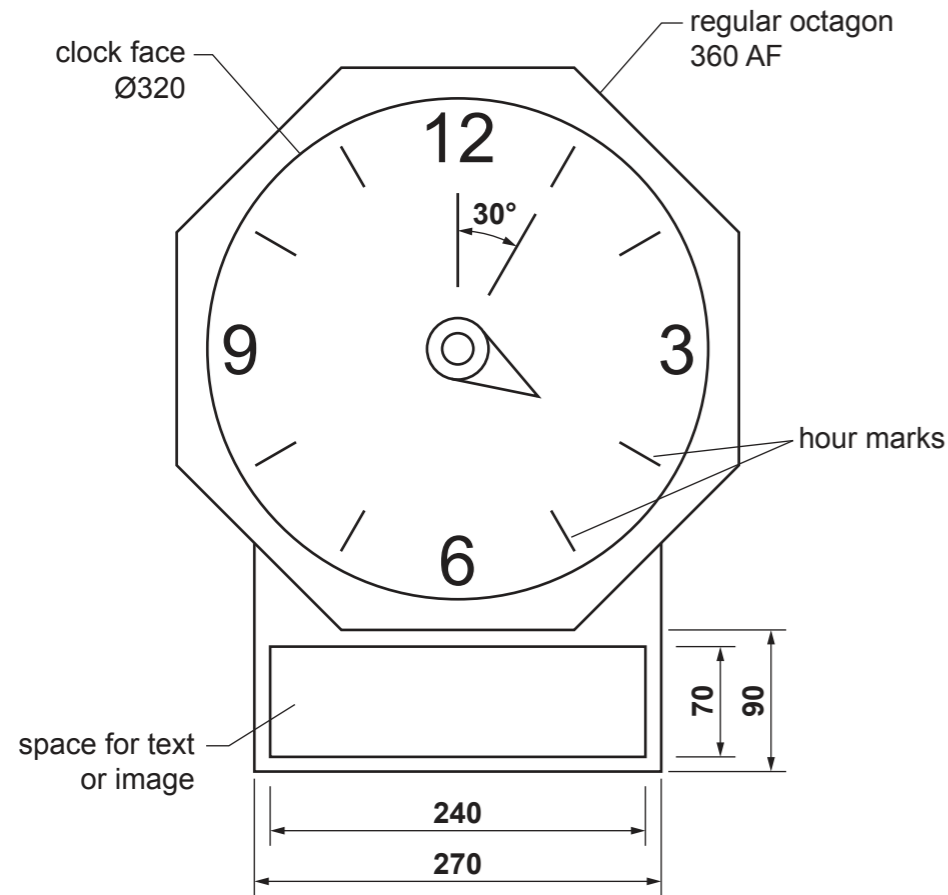

- (a) Complete the drawing of the wall clock in the space provided to the right to a scale of 1:2 by adding:
- (i) the outline and clock face [8]
 - (ii) the rectangular space for an image [2]
 - (iii) the missing hour marks and number 12. [4]

(b) The minute hand for the clock is shown below.

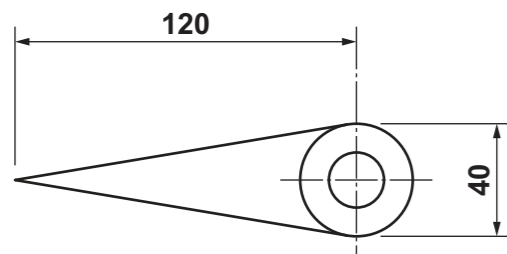

Add the minute hand to the clock face in a vertical position to a scale of 1:2. [3]

For Examiner's use

0445/53 Oct/Nov 2021 **1 hour**
© UCLES 2021 DC (KS/CB) 200330/5

Centre Number Candidate Number Candidate Name [Turn over]

A2 The rectangular space below the clock face allows the clock to be 'personalised' by adding an image.

(a) Describe how a computer would be used to obtain a printed image that could be applied to the rectangular space on the clock.

.....

 [3]

(b) The image of the sports car shown below is to be applied to the rectangular space below the clock face.

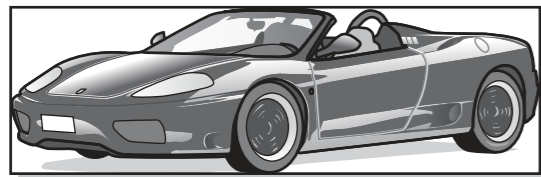

Before the image can be applied it must be enlarged.

In the table below, tick (✓) the largest scale that the image can be enlarged by to fit into the 240 × 70 rectangular space on the clock.

Scale	Tick (✓) one
2:1	
3:1	
5:1	
1:3	

[1]

A3 The enlarged image of the sports car has been produced as a dry transfer.

Complete the flow chart to show the process of applying the dry transfer image of the sports car to the rectangular space on the clock.

[4]

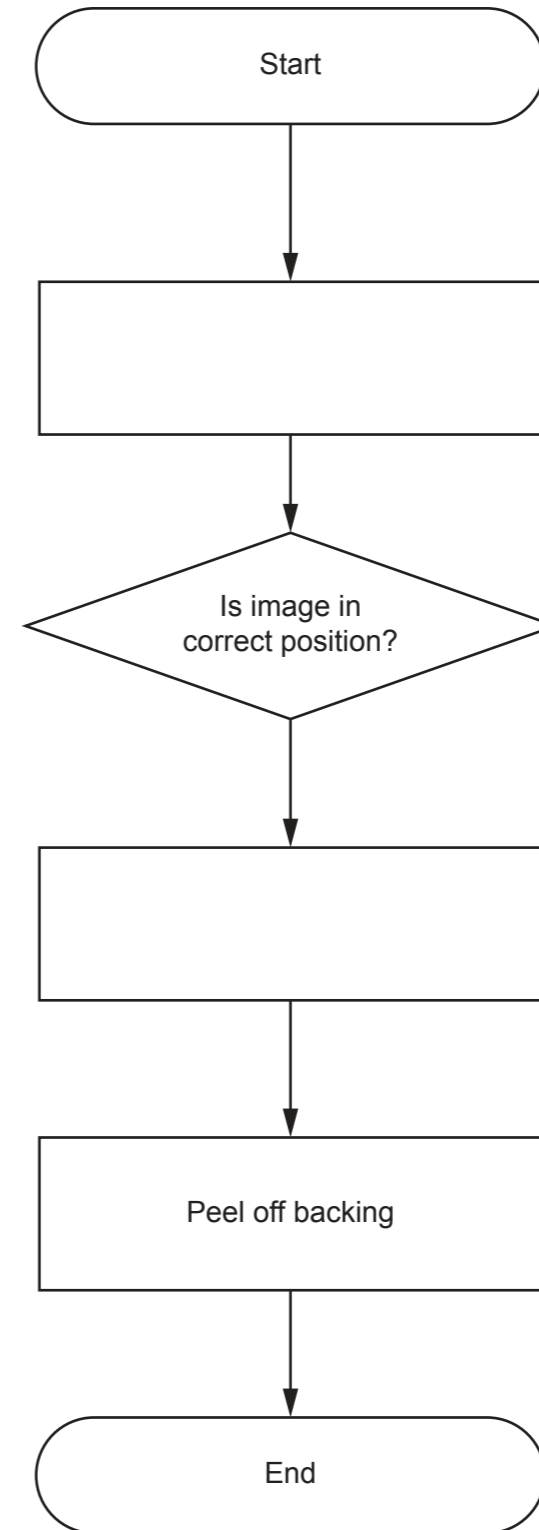

Section B

Answer **one** question, **either** question **B4** or **B5**, from this section.

B4 The wall clock shown below is made from the three different parts shown in the table.

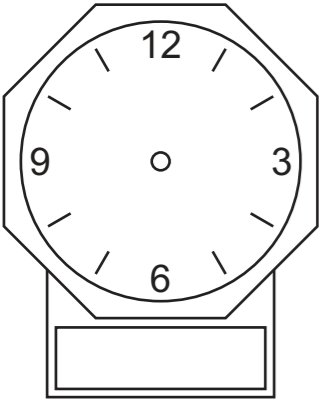
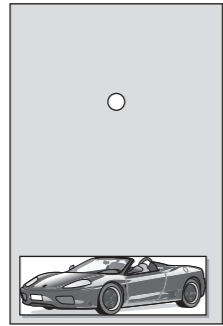
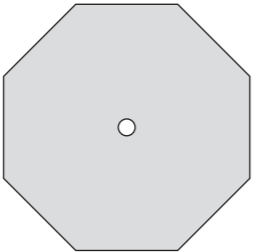
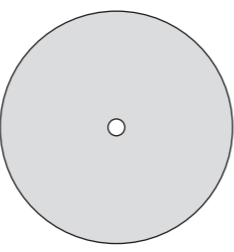
	Back board	Main body	Clock face
	18 mm hardwood 390 mm × 270 mm	18 mm hardwood 360 mm AF	0.2 mm sheet plastic
			

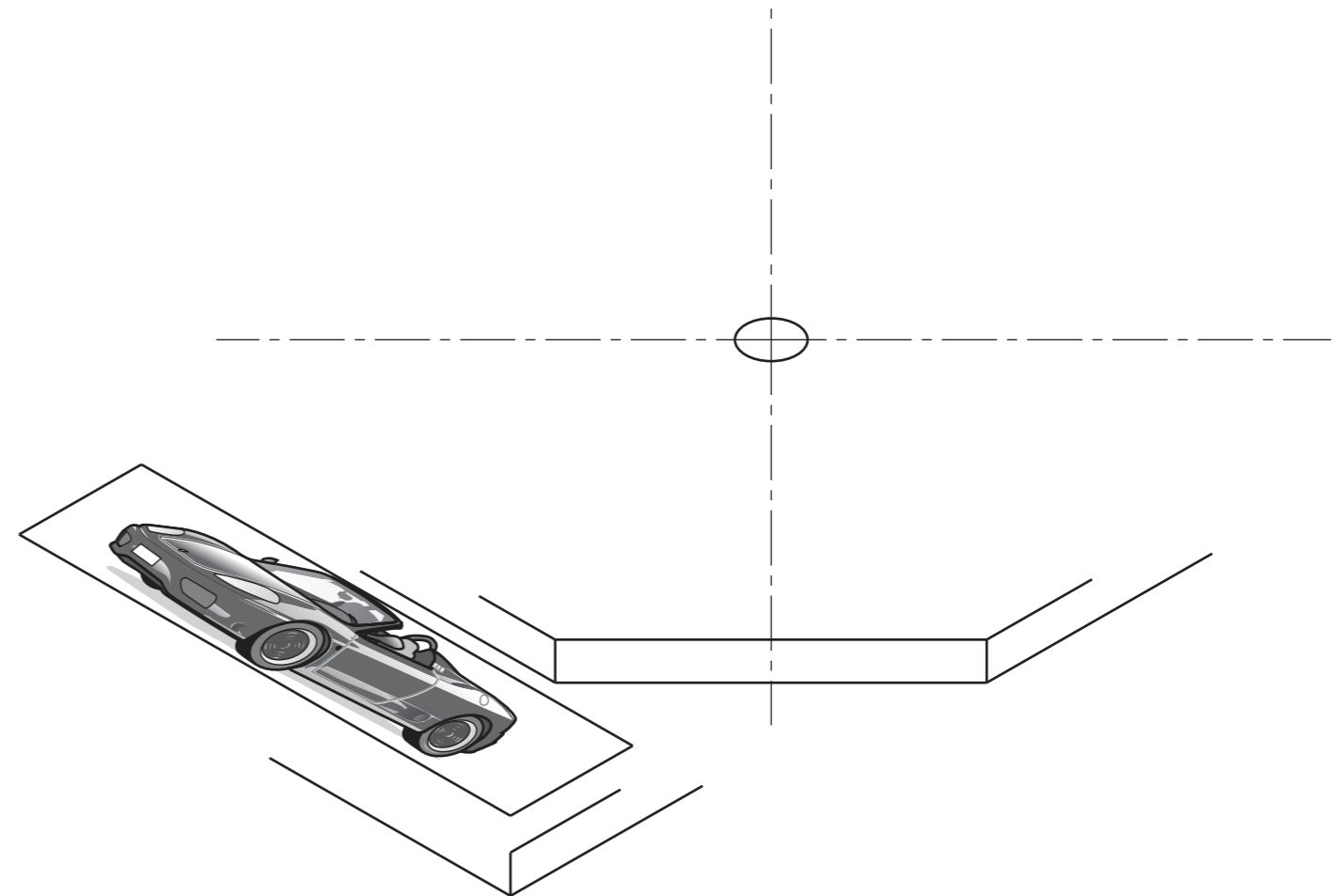

(a) Complete the isometric view of the assembled parts to a scale of 1:3 in the space to the right by adding:

- (i) the back board [4]
- (ii) the main body. [7]

(b) Complete the full-size outline of the clock face by adding an ellipse to the given axis lines.
Major axis 130
Minor axis 76 [6]

(c) The mechanism for the wall clock is shown below.

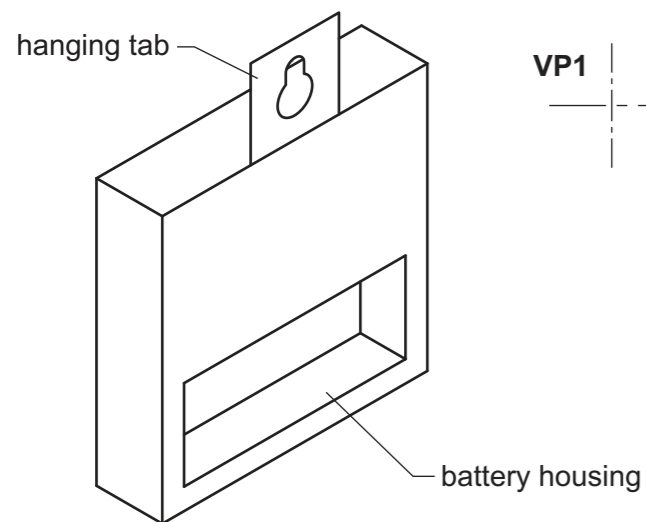

VP1

VP2

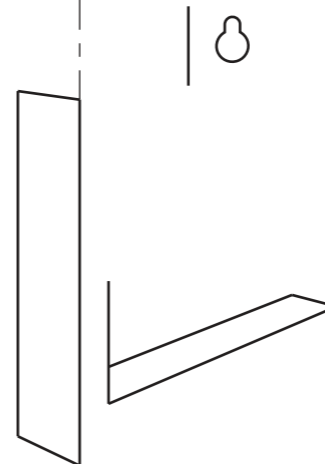

Complete the estimated two-point perspective view of the clock mechanism shown to the right.

[8]

0445/53 Oct/Nov 2021 **1 hour**
© UCLES 2021 DC (KS/CB) 200330/5

Centre Number

Candidate Number

Candidate Name

[Turn over

For Examiner's use

B5 Orthographic views of a digital clock are shown below.

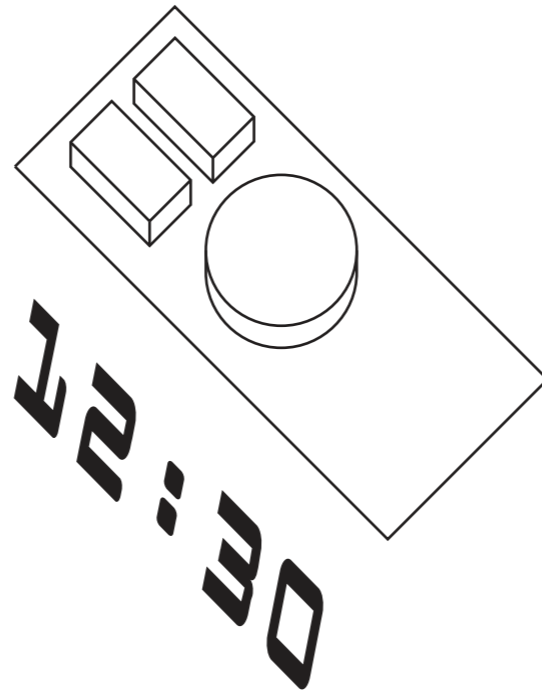
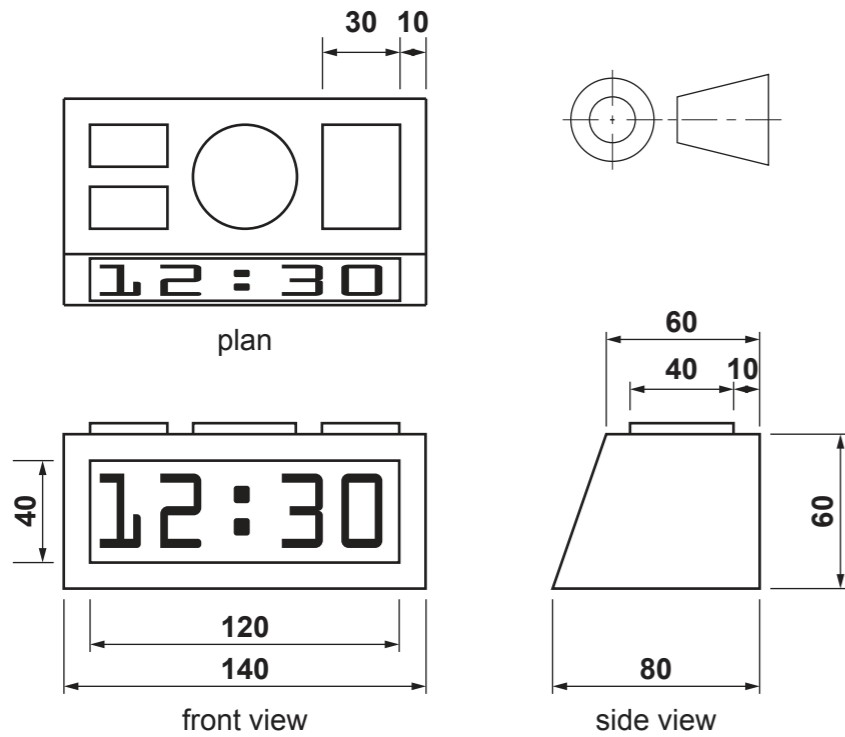

(b) The Styrofoam insert shown below protects the digital clock from damage during transportation and storage.

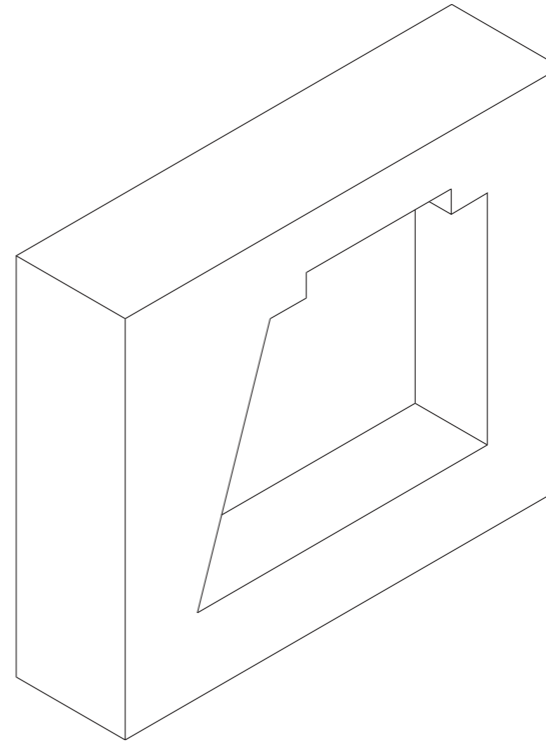

(i) Apply thick and thin line technique to the Styrofoam insert. [5]

(ii) The Styrofoam inserts are to be manufactured in quantities of 10 000.

State the process used to mass produce the Styrofoam inserts.

..... [1]

(iii) Give **one** property of Styrofoam that makes it suitable for the insert.

..... [1]

(a) Complete the planometric view of the digital clock to a scale of 1:2.

[9]

(c) The digital clock and inserts are packaged inside the cardboard box shown below.

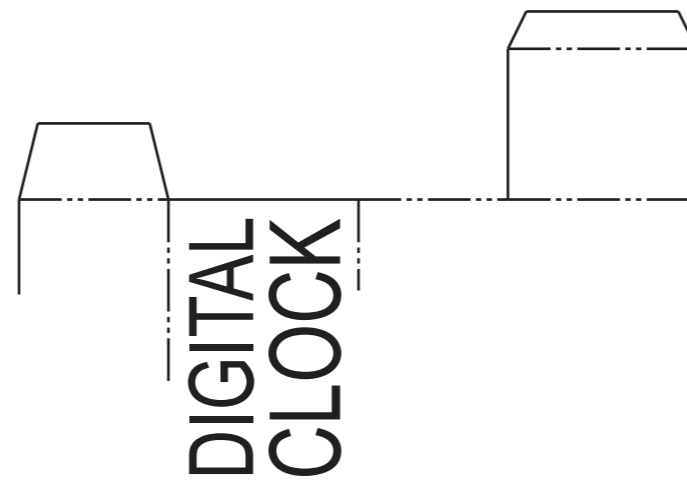
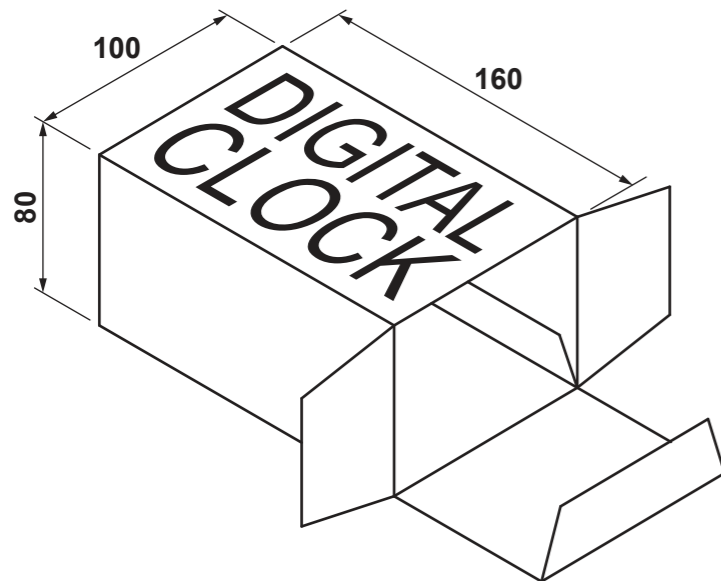

Complete the development (net) of the digital clock package to a scale of 1:4.

[6]

(d) In use, the box for the digital clock comes open too easily.

Use sketches and notes to show a method of temporarily securing the end of the box closed without the use of adhesives.

[3]